

Original Parts & Accessories

Installation Instructions



BMW R1100S Sport Rear Stand – Replacement ‘Spool’ Kit Part Number: 82 00 0 419 572

Rear Stand Spool Kit Overview:

Replacement engaging receivers (spools) attached to the motorcycle at existing center-stand mounting holes in the frame rails allow one stand to be utilized for more than one motorcycle.



- ‘Spools’ can be installed, configured in different ways to accommodate motorcycles with, or without, engine spoilers (lower bodywork) installed.

These instructions must be read carefully and thoroughly before installation or use.

- BMW of North America, LLC and BMW Motorrad USA accept no liability for damage caused by failure to observe the installation instructions.
- BMW Motorrad USA recommends that an authorized BMW Motorcycle Retailer perform this installation. Before installation, one should carefully consider whether one is in possession of the necessary technical skills and workshop tools to complete the installation properly. If not, any BMW Motorcycle Retailer will gladly perform the installation.

- | | | | |
|---|--|-----------------------------------|-------------------------------|
|  | Special Tools needed for installation: | • 6mm allen (internal hex) wrench | • 5/16 (or 8mm) drill bit |
| | | • Electric drill | • ‘Blue’ Thread-lock compound |

The following symbols are used in these instructions for safety notes:



 Warning	 Caution	 Note
Warning indicates a potentially hazardous situation, which if not avoided, could result in death or injury.	Caution indicates a potentially hazardous situation or unsafe practice that may cause property damage or may invalidate your vehicle warranty.	Tips for facilitation of operation, control and adjustment, as well as maintenance work.

Installation Overview:

Spool installation can be configured to accept motorcycles:

1. Without any lower spoiler installed (*Diagram ‘A’, below*).
2. With Factory CF Lower Spoiler Kit (PN 71 60 7 682 326) installed (*Diagram ‘A’, below*).
3. With Factory CF Belly Pan as per BMW R1100S ‘Replika’ installed (*Diagram ‘B’, below*).

The kit includes all of the necessary hardware for these two configurations. See diagrams that follow for details.

	Caution: Stand spools must be installed on the motorcycle as per the appropriate diagram. DO NOT ATTEMPT TO MODIFY THE INSTALLATION.
	Note: If the motorcycle is equipped with a factory installed center stand, both it, and the ‘pressed-in’ frame bushing must be removed to allow installation and operation of the Sport Rear stand. In this situation, BMW Motorrad USA recommends contacting your authorized BMW Motorcycle Retailer for assistance.
	Warning: These instructions are for replacement spool installation only. Before using the rear stand, review all cautions and warnings included in Rear Stand Kit (BMW PN 82000419570) instructions available from authorized BMW Retailers.

Installation Procedure:

- R 1100 S models without spoiler
- R 1100 S models with Factory CF Spoiler (PN 71 60 7 682 326) installed.

DIAGRAM 'A'

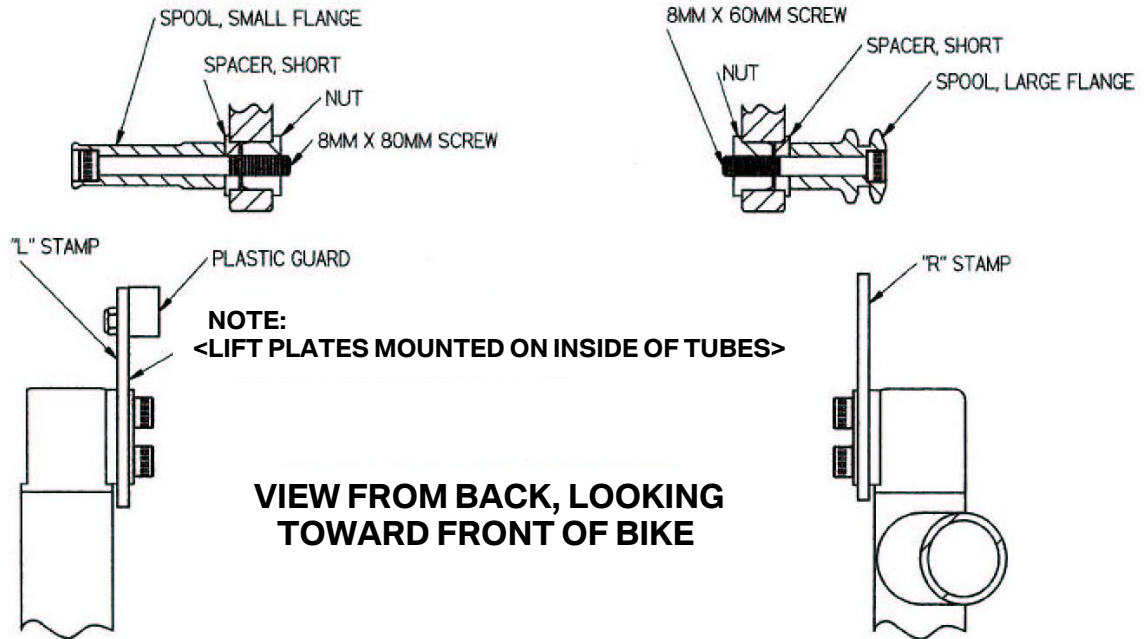

1. Park the motorcycle on a smooth, dry and level surface using the standard side stand. Ensure that the ignition and steering lock are OFF and the motorcycle is in gear.
2. Locate the Center Stand mounting holes in the frame on either side of the bike.
3. Position the special backing nuts in the **back** of the center stand mounting holes and draw them completely into the hole utilizing the short 8mm screw and short spacer provided (image a, b, c)
4. With the backing nuts installed, continue installing the remainder of the hardware referring to **DIAGRAM 'A'** (above).
 - Once the stand spool receivers are installed, re-install the Sport Spoiler, if utilized.

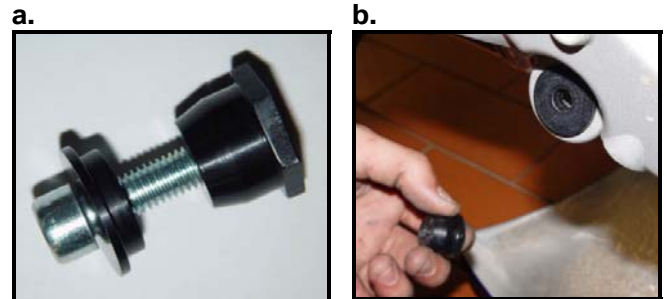

Note: Secure spool attachment bolts with thread-locking compound, e.g. Loctite 'Blue', not supplied.

Installation Procedure:

➤ R 1100 S models with 'Replika CF Bellypan Installed.

DIAGRAM 'B'

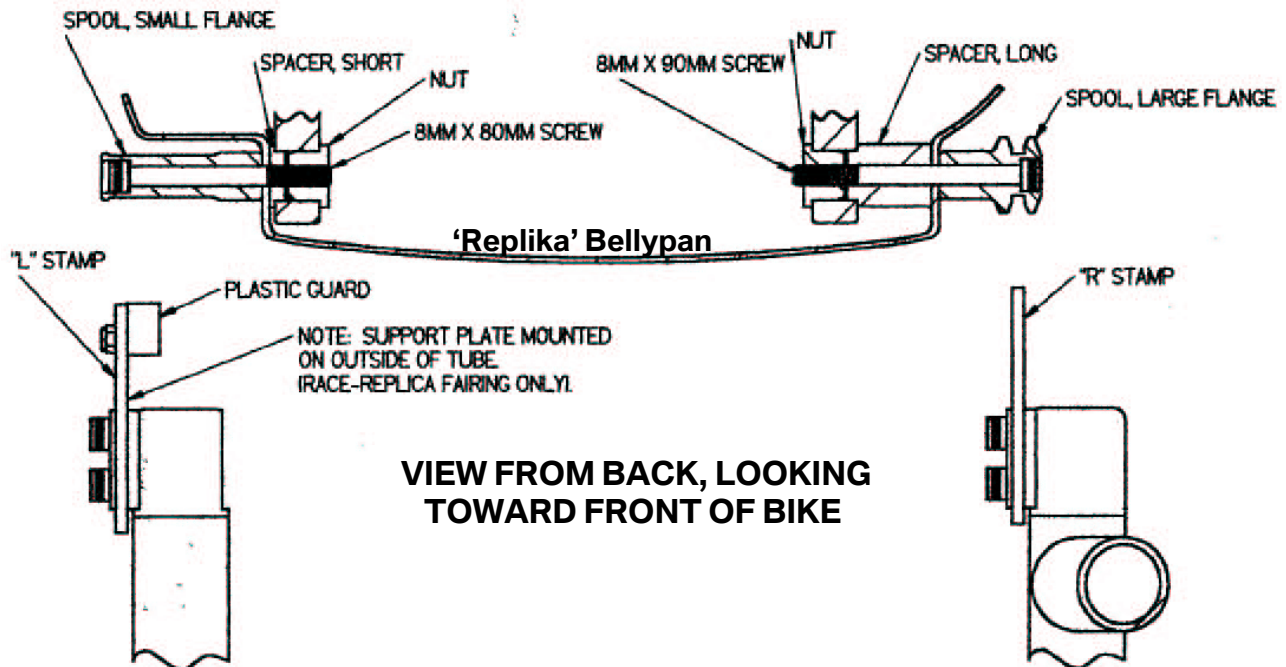

1. Park the motorcycle on a smooth, dry and level surface using the standard side stand. Ensure that the ignition and steering lock are OFF and the motorcycle is in gear.
2. Carefully remove the bellypan. Place aside on a protected surface to avoid possible damage to the bellypan.
3. Remove rear rubber bellypan support plugs from both sides of frame. Store parts for future use.
4. Position the special backing nuts in the **back** of the center stand mounting holes and draw them completely into the hole utilizing the short 8mm screw and short spacer provided (image d, e).
5. Before re-installing the bellypan, both existing mounting holes, one in each side, must be enlarged carefully using a 5/16 inch or 8mm drill to allow clearance for the spool mounting bolts.
6. Install the remainder of the hardware and reinstall the bellypan, referring to ***DIAGRAM 'B'*** (above).

d.



e.



f.



Note: Secure spool attachment bolts with thread-locking compound, e.g. Loctite 'Blue', not supplied.